



- 100 - 277V AC Supply Voltage
- Two pre-configured alarm and control thresholds
- Thresholds factory set to customer requirements
- Non dispersive infrared sensing technology
- Optional internal audible alarm
- Digital display of carbon dioxide levels (ppm)
- Alarm status indicator lights
- Sensor fault indication

Application

The Duomo Carbon Dioxide Alarm has been developed to control and protect against the build up of carbon dioxide in environments where ventilation is essential to occupant safety and comfort such as; commercial catering establishments, science laboratories, classrooms, offices, cellars and more.

This is a wall mounted, stand alone carbon dioxide alarm. It has two thresholds which can be pre-configured to switch the two on board alarm relays at any required level of carbon dioxide up to 10,000 ppm.

Control and alarm threshold levels may vary.

At Duomo we can configure the switching points to suit your personal preference.

The CO₂ Alarm has an onboard digital display, alarm status indicator lights and optional audible alarm.

Operation

When carbon dioxide levels rise to alarm threshold one an output at the supply voltage (100-277V AC) is generated.

This is usually used for automatic ventilation control or remote alarm indication.

The second relay changes over if carbon dioxide levels continue to rise.

The second alarm contact can be used to either break the circuit to a combustion control or, in the case of commercial kitchens, break the supply to the gas safety shut off valve.

At the second alarm threshold the audible alarm will sound (if fitted).



Carefully read the following instructions prior to installation of this device. Always keep this pamphlet for future reference. Always isolate the electrical supply before opening.

Installation Instructions

The Duomo CO₂ Alarm can be mounted on a standard double back box. To fit the enclosure it is necessary to remove the power module and the printed circuit board (PCB) (see Page 4). To open the enclosure see page 3.

Fix the empty enclosure to the double socket back box (not included) then screw the power module back into position and click the PCB into place.

Connect the electrical supply voltage; 230V AC live (Ph) to terminal A and neutral to terminal B.

The first alarm terminal C becomes live in alarm. Therefore it can be connected to a remote audible flashing alarm e.g. the Duomo AF126. Alternatively this alarm level can be lowered to provide a comfort control output to open vents or boost fans etc. This level can only be adjusted by Duomo engineers prior to despatch. See model selection guide on page 6.

The second alarm terminals D and E break the circuit in alarm. This pair of terminals are volt free so can be used to isolate the electrical supply to a gas valve. This alarm can also be configured to close in alarm. Again this modification can only be made by Duomo engineers prior to despatch. See model selection guide on page 6.

Wiring Diagram

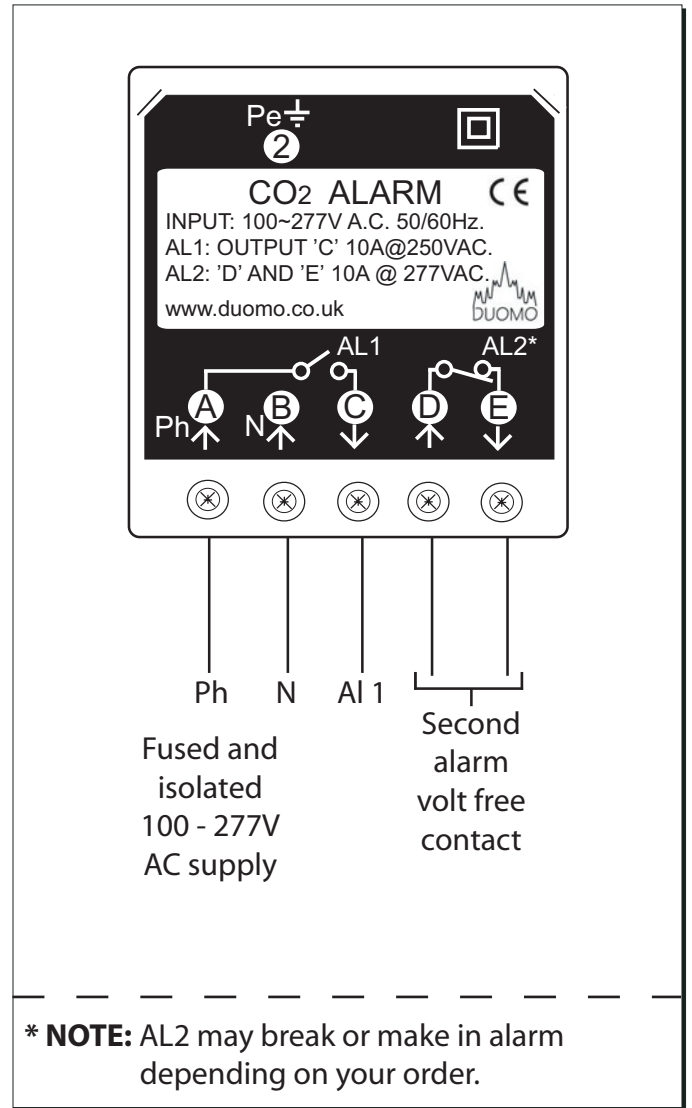

Carbon Dioxide Alarm Layout & Dimensions

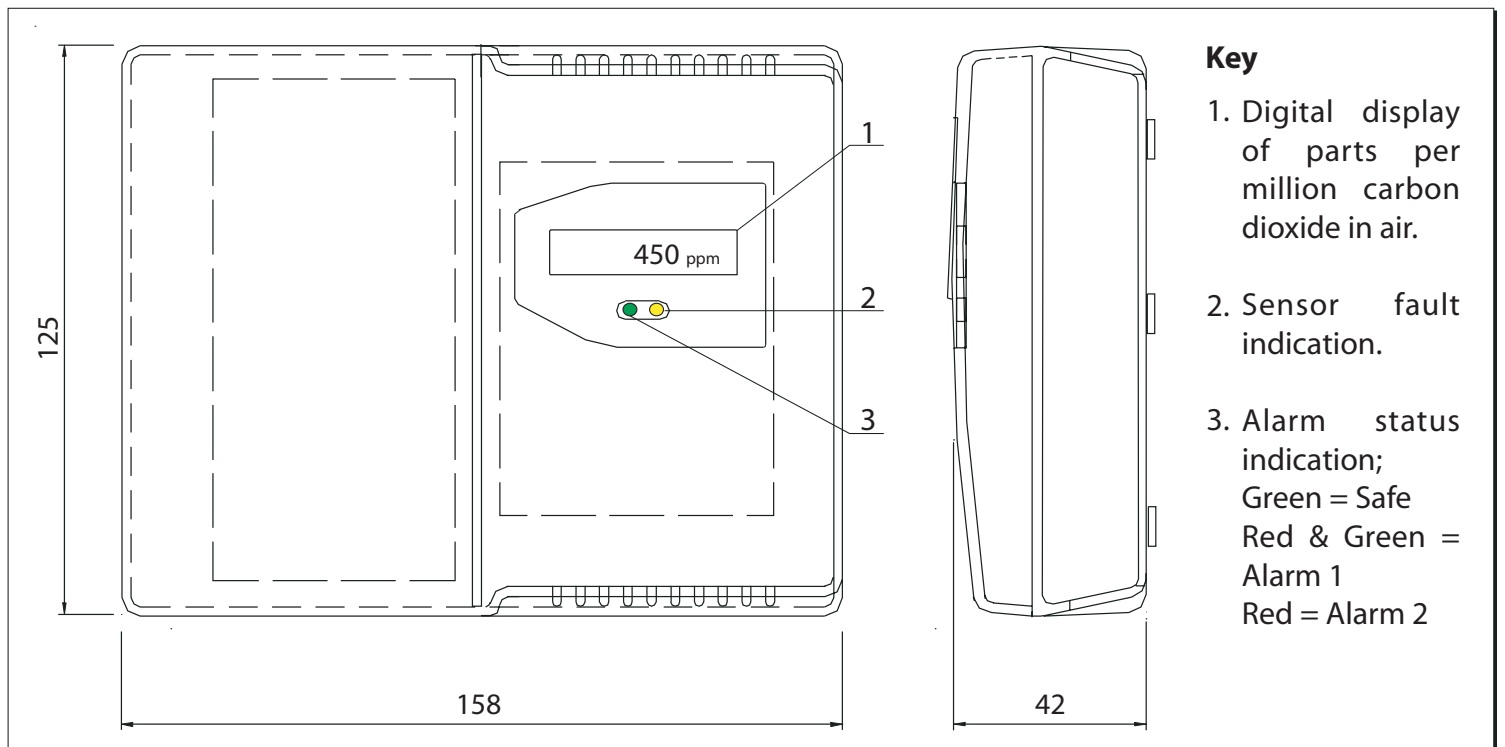

How To Remove The Enclosure Lid

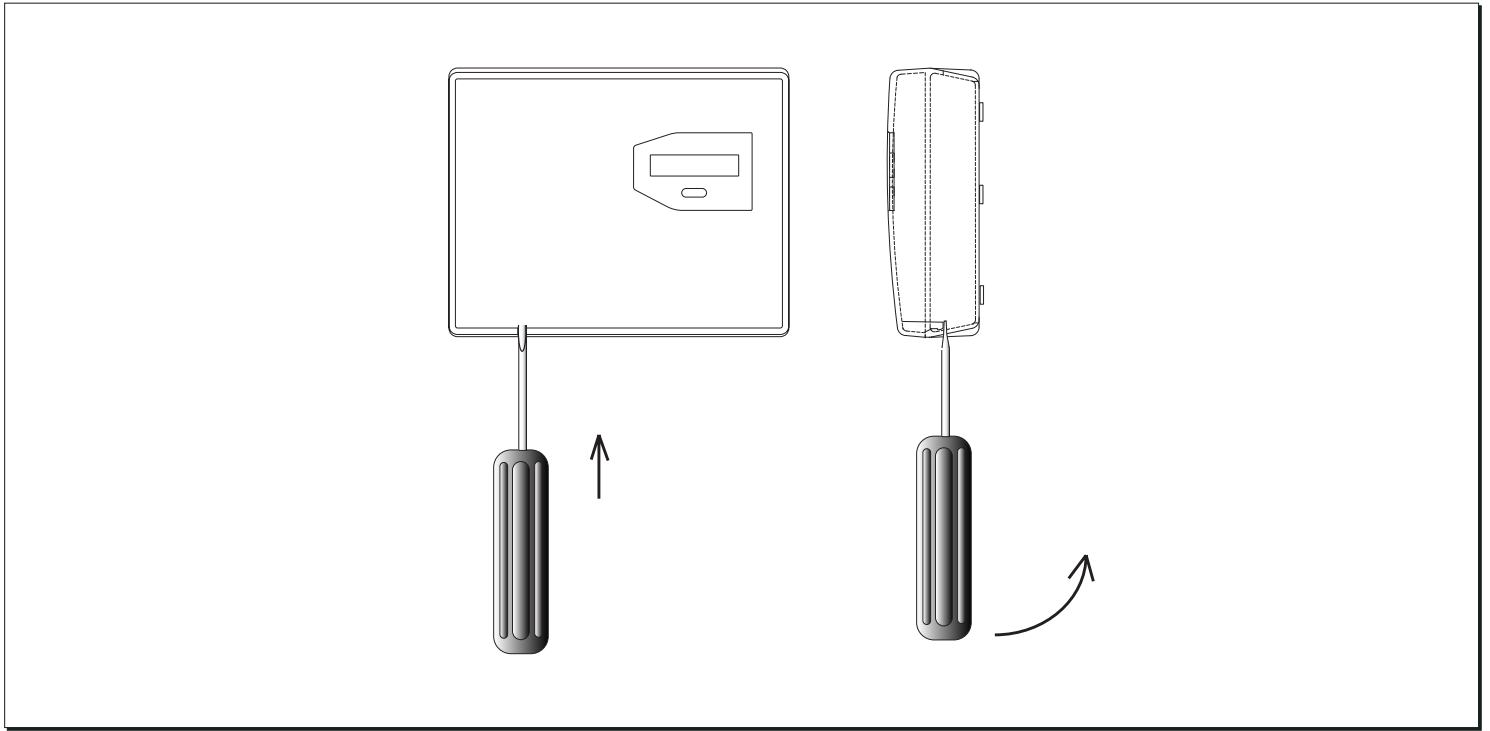

Note: Turn off the power to this unit before opening the enclosure

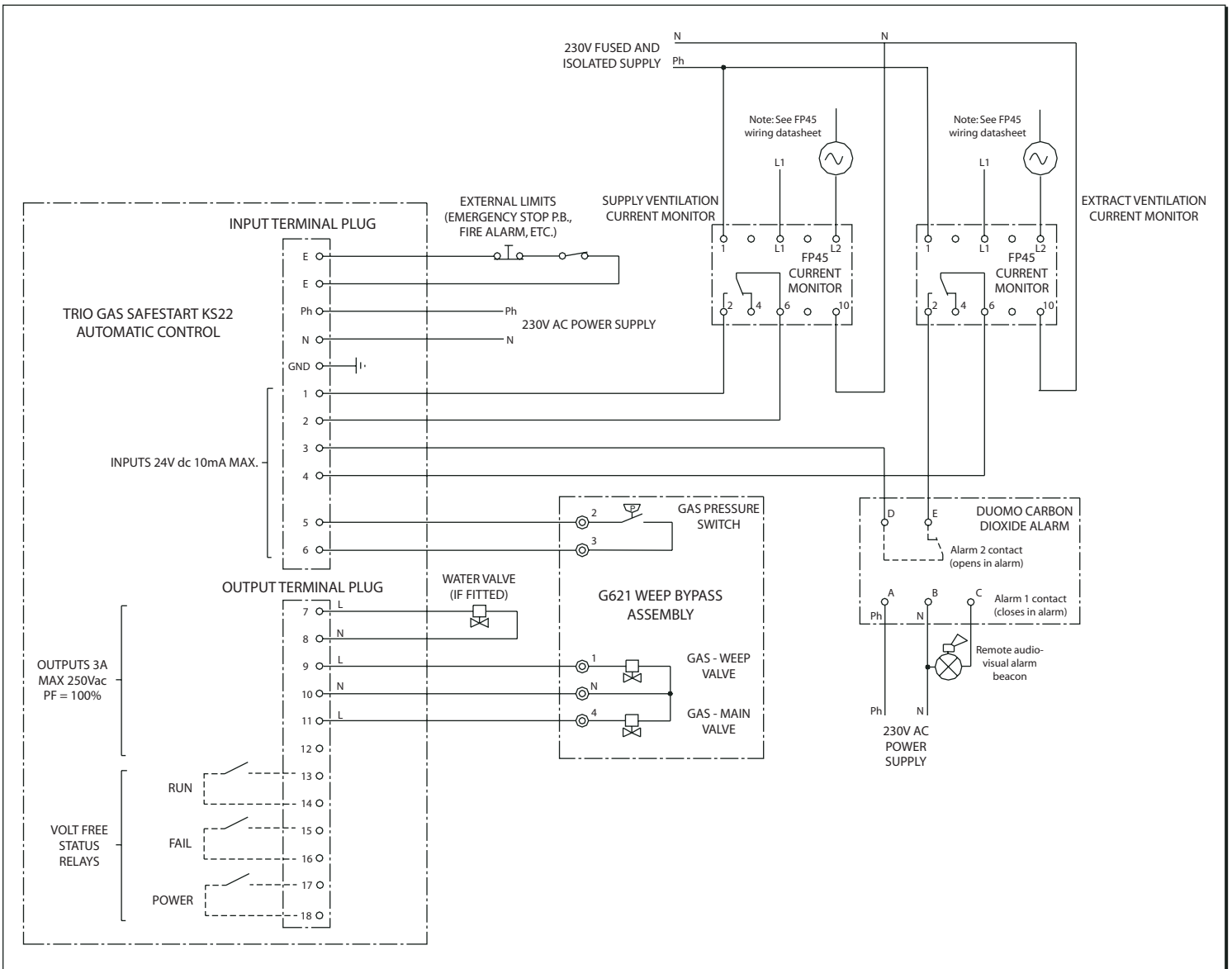

Commercial Kitchen - Typical connection with KS22 Trio and current monitor ventilation proving

Carbon Dioxide Alarm Internal Arrangement

To remove the power module unscrew the fixings shown

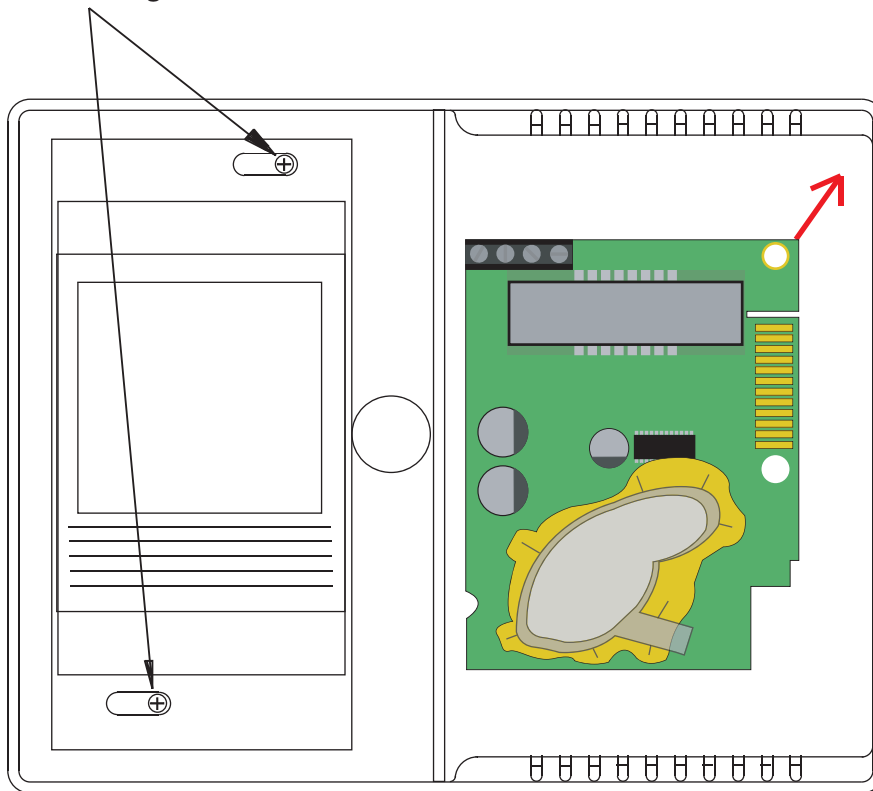

To release the PCB carefully push the retainer in the direction shown (see picture to the left) until it unclips. The board can then be withdrawn from the enclosure.

Fixing positions and cable entry point

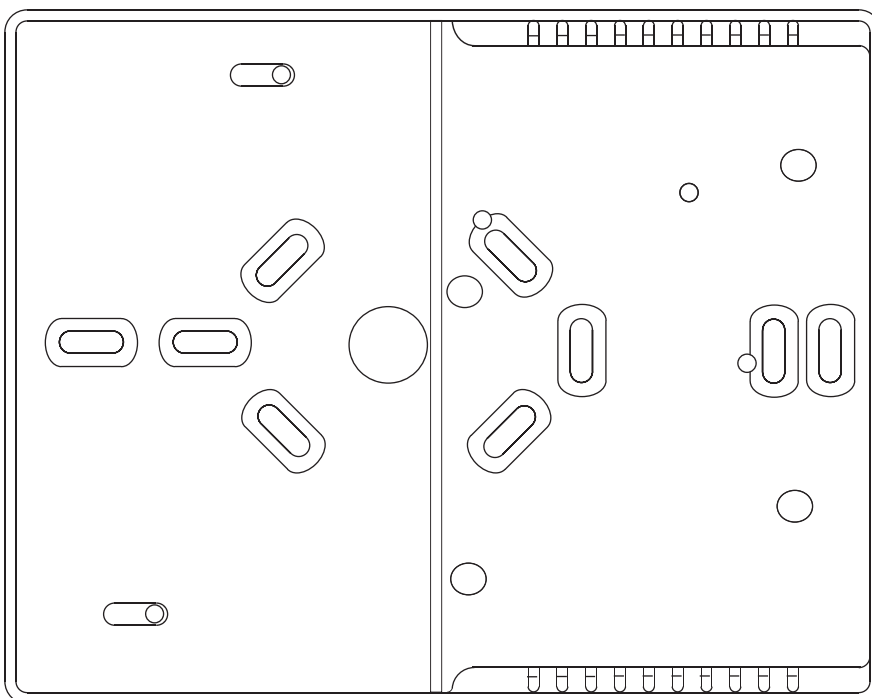

Note:

These fixing points are compatible with single and double gang back boxes.

Recommended cable type is tri-rated 1mm² cross sectional area (csa).

Operating Instructions

The Duomo Carbon Dioxide Alarm has two alarm thresholds. These are configured prior to despatch from Duomo to suit customer requirements (see last page for order form). The default settings are for a commercial catering establishment. They are as follows;

- Alarm 1 on @ 2800ppm - Alarm 1 off @ 2500ppm
- Alarm 2 on @ 5000ppm - Alarm 2 off @ 4500ppm

When power is applied to terminals A and B, the green light will illuminate and the digital display will show all symbols. This display will then change to 'HEAT' for approximately 5 seconds. The display will then change to read the current ambient levels of carbon dioxide in the air.

Alarm 1 (Terminal C)

This output becomes live at the supply voltage when the pre-set threshold is reached. This output can be connected to a vent opening device, ventilation fan or a remote alarm indicator. There is no on-board audible alarm associated with this output. The status of the alarm is indicated by the green light flashing red and green alternately. This alarm output will stop when the levels of carbon dioxide drop below the alarm off threshold.

Alarm 2 (Terminals D and E)

Available with either a normally open or normally closed contact. This contact actuates should levels reach the second alarm threshold. This contact is rated at 10 A at 277V AC. The purpose of this alarm is to break the circuit to the gas supply valve or make the circuit to sound remote alarms. This alarm will reset when the levels of carbon dioxide drop below the level 2 alarm off threshold.

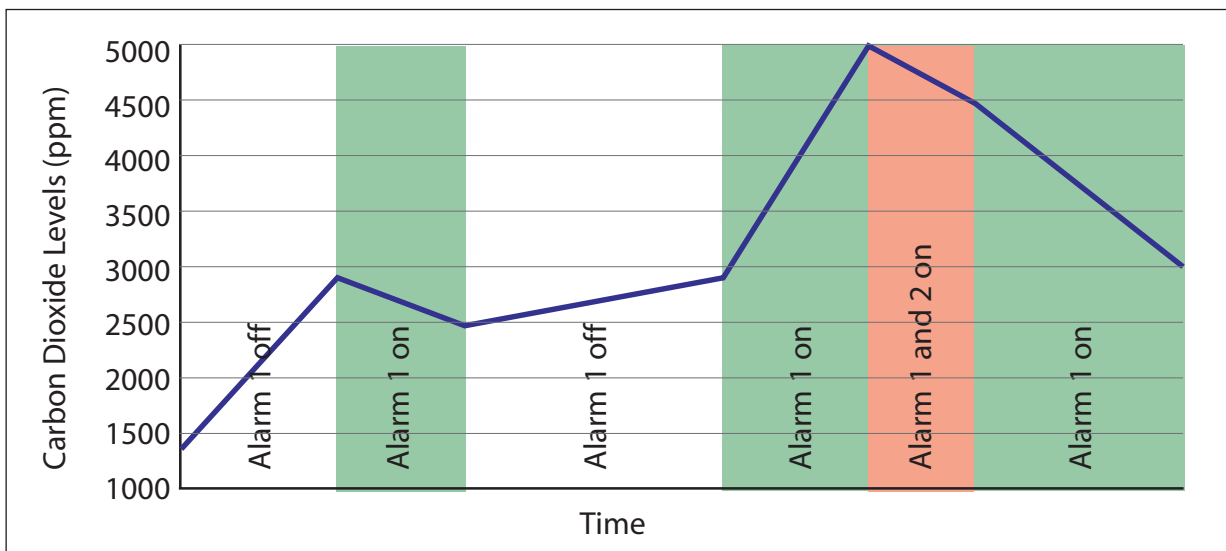

Guarantee

This device is guaranteed for a period of 2 years from the year of production (applicable for a 12 month extension).

Conditions;

Substitution or repair free of charge of any component recognised as being faulty from production. The unit must be delivered to the resaler or directly to Duomo.

Note:

All wiring must comply with relevant local electrical standards. The installation of this product should only be undertaken by qualified personnel.

Duomo (UK) Ltd will not be held responsible for any damage to property or personnel resulting from incorrect installation. If you are in any doubt regarding the installation or function of this product please call our Technical Department on 01905 797462.

CO2 Alarm Model Selection

| | | | | | | |
|-----------------------------|---|--|--|--|--|--|
| Carbon Dioxide Alarm | | | | | | |
| Carbon Dioxide Alarm Levels | | | | | | |
| Alarm 1 on at _____ ppm | | | | | | |
| Alarm 1 off at _____ ppm | | | | | | |
| Alarm 2 on at _____ ppm | | | | | | |
| Alarm 2 off at _____ ppm | | | | | | |
| Alarm 2 actuation method | | | | | | |
| Make in alarm | M | | | | | |
| Break in alarm | B | | | | | |
| Audible alarm | | | | | | |
| With audible alarm | A | | | | | |
| No audible alarm | - | | | | | |

Name: _____

Company: _____

Contact no.: _____

Please complete this order form and fax it back to us on
01905 774296.

