

# GS100M Gas Detection Controller



## GS100M 1 Channel Gas Detection Controller

1

Channel

Conventional

Positive Safety

4-20mA

IP44



## FEATURES

- Single channel protection
- 230VAC supply
- Wall or panel mounted
- Positive safety option
- Detection of Toxic 0-300ppm / Explosive Gas(es) 0-20%LEL /
- 4-20mA signal sensor input
- 3 alarm stages - 1<sup>st</sup> & 2<sup>nd</sup> pre-alarm and main alarm
- IP44 protective rating
- CE certified and approved to EN 61010-1, EN 50270, EN 50271, EN 45544-3, EN 60079-29-1
- 2 year guarantee - 3 year by registering at [duomo.co.uk](http://duomo.co.uk)

## OVERVIEW

The GS100M is a 230V three channel and sensor wall or panel mounted gas detection controller. It can be connected to toxic and explosive sensors. An LED display indicates sensor status and faults.

If the remote sensor senses the presence of gas, it sends a proportional 4-20mA signal back to the GS100M. When the first alarm level is reached the pre-alarm relay is activated (See Alarm Settings). If the level continues to rise the main alarm relay will be energised.

For explosive or toxic gases, the electrical supply to the safety shut off valve is broken when the main alarm threshold is reached. A general alarm is sounded.

Should the controller enter fault condition the safety shut off valve closes to fail safe. A self-diagnostic feature looks for return sensor voltage and ensures correct functionality.

The GS100M controller is compatible with all the Duomo conventional sensors.

## SPECIFICATION

### Power

Power Supply	230VAC 50Hz ± 10%
Secondary Battery	12VDC ± 10% Max 2.2Ah
Battery Charger	Charger Capacity 2.2Ah
Power Consumption	11W Maximum @ 13.8V
Relay Contact Range	10A resistive

### Alarm Settings

Pre-Alarm No.1	8% LEL / 120ppm
Pre-Alarm No.2	13% LEL / 200ppm
Main Alarm	Fixed at 20% LEL / 300ppm
Sensor Fault	Short circuit, interruption, sensor deterioration

### Technical Specification

Dimensions	Width 144mm   Height 144mm   Depth 110mm
Display	N/A
Mounting	Wall or panel mounted
Input Signal	4-20mA
Device Precision	1% FS
Reaction Time	<10 seconds
Working Temperature	-10°C to 40°C
Start-up Self-Diagnostic Delay	90 seconds
Protective Rating	IP44

### Configuration

Positive Safety	Yes (ON/OFF)
Main Alarm Relay Actuation	Yes (Latching/Temporary Alarm)
Gas Type Selection	Yes (Toxic/Explosive)
Timed Sensor Test Facility	No
Emergency Stop Connections	No
O <sub>2</sub> Compatibility as Standard	No

### Peripheral Specification

No. of Remote Sensors	1
Maximum Sensor Distance	100m
Cable Diameter for Sensors	1mm <sup>2</sup> CSA (Screened and earthed at the controller end)

### Compatibility

Sensor Compatibility	All Duomo Sensors
----------------------	-------------------

### Approvals, Certifications and Guarantee

Approvals	EN 61010-1, EN 50270, EN 50271, EN 45544-3, EN 60079-29-1
Guarantee	2 year as standard 3 year by registering at <a href="http://www.duomo.co.uk">www.duomo.co.uk</a>



## Overview

The GS100M is a wall or panel mounted microprocessor based gas detector control unit. The GS100M can be configured to meet customer requirements. The following parameters can be changed using on board DIP switches: **(See Configuring the GS100M)**

- Sensor (on or off)
- Type of gas to be sensed (explosive or toxic)
- Positive Safety Option (on or off)
- Main alarm relay action (permanent or temporary)

The GS100M has one fault relay that breaks the connection in case of system failure. This can be used to constantly monitor the operation of the controller remotely (eg through a BMS). The relay driving technology (de-energized when triggered) will ensure a prompt indication even in case of mains power failure.

The GS100M has two plug in terminal blocks. One is for the incoming mains supply and alarm circuit wiring and the second is for connecting the sensor wiring.

This reduces the chance of incorrect site wiring. The front panel has two overload lights which indicate when a short circuit or an overload has occurred on the sensor wiring.

## Overall Dimensions (mm)

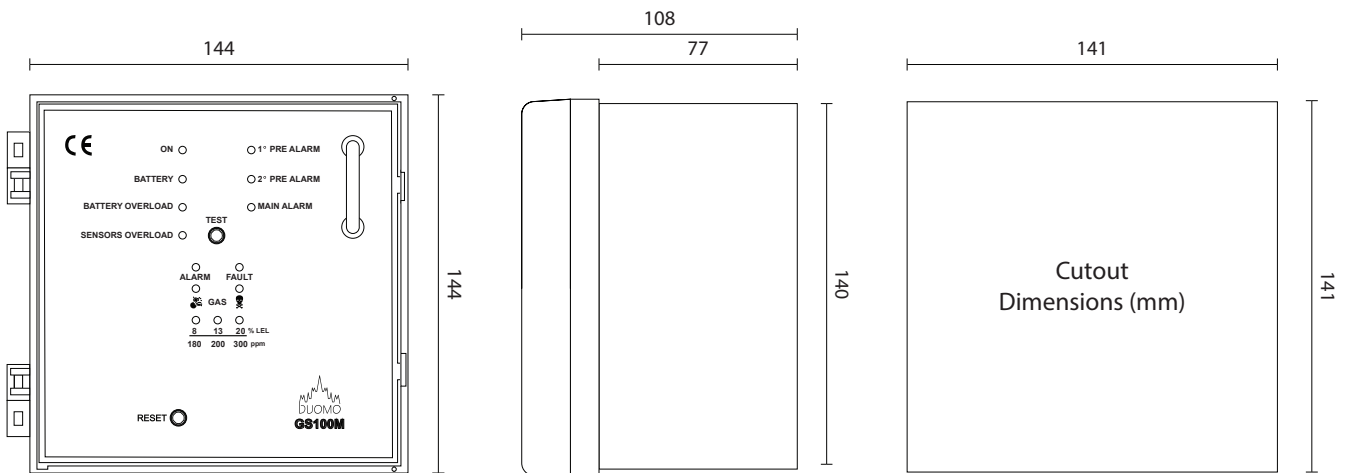

## Mounting the GS100M

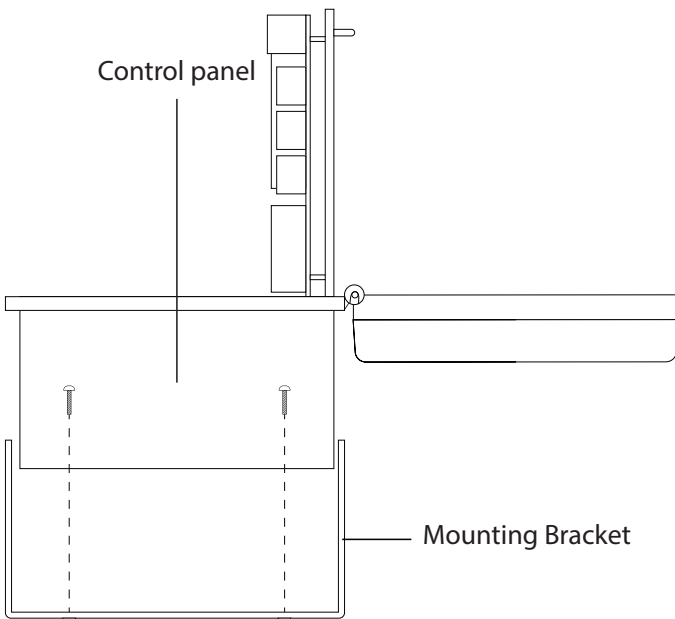

# GS100M Fascia & PCB Layout

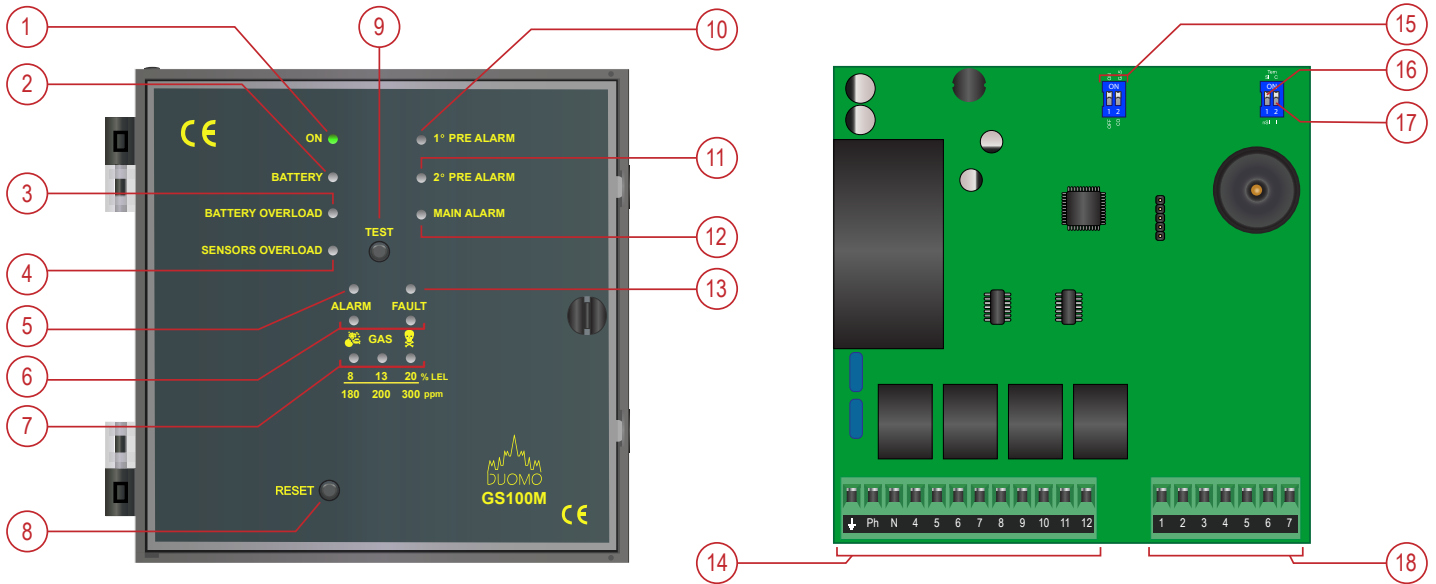

No	Description	Purpose & Functionality
1	ON	LED illuminates when supply voltage is applied. LED flashes during self diagnosis start up.
2	BATTERY	This LED illuminates when the GS100M is being poered by standby battery
3	BATTERY OVERLOAD	LED Illuminated to indicate incorrect battery connection or high consumption during charging phase.
4	SENSORS OVERLOAD	LED Illuminated to indicate short circuit or overload on sensor circuitry.
5	ALARM	Indicates alarm status (explosive or toxix levels have been reached)
6	TOXIC / EXPLOSIVE	Toxic (Skull) LED illuminates when DIP switch for sensor is in CO (Toxic) position Explosive LED illuminates when DIP switch for sensor is in GAS (Explosive) position
7	PRE ALARM LEDS	Indicate level of gas sensed (8 - 13 - 20% LEL / 120 - 200 - 300ppm)
8	RESET	When pressed resets the detector after an alarm or sensor fault condition.
9	TEST	When pressed checks the sequence and function of GS100M. Press and hold to initiate a full function test, release once controller is in alarm state required <b>Will eventually activate all relays and their associated outputs.</b>
10	1 <sup>st</sup> PRE ALARM	Illuminates at 8% LEL (Explosive) or 120ppm (Toxic) gas concentration: LED illuminates and the Pre Alarm relay 1 is actuated.
11	2 <sup>nd</sup> PRE ALARM	Illuminates at 13% LEL (Explosive) or 200ppm (Toxic) gas concentration: LED illuminates and the Pre Alarm relay 2 is actuated.
12	MAIN ALARM	Illuminates at 20% LEL (Explosive) or 300ppm (Toxic) gas concentration: LED illuminates and the Main Alarm relay is actuated.
13	FAULT	Indicates short circuit, sensor fault, loss of signal or incorrect sensor connection.
14	Supply & Relay Terminals	Electrical supply and relay connections. <b>(See Wiring Schematic for connection instructions).</b>
15	Sensor switch	Used to enable or disable the sensor zone (ON/OFF) or determine type of gas to be detected (Toxic/Explosive) - <b>(See Configuring the GS100M section for setting instructions).</b>
16	Positive Safety switch	Positive Safety switch <b>(See Configuring the GS100M section for setting instructions).</b>
17	Main Alarm Relay actuation	Determines if Main Alarm relay remains in position even if gas levels drop below alarm threshold. <b>(See Configuring the GS100M section for setting instructions).</b>
18	Sensor/ Battery Terminals	Sensor and Battery (if fitted) terminals <b>(See Wiring Schematic for connection instructions).</b>

# Configuring the GS100M

The GS100M has two pairs of DIP switches on the PCB. The left switch on first three double switches is used to enable or disable the sensor for that respective zone. The right switch is used to configure the controller to indicate whether the connected sensor is for explosive or toxic gas.

The GS100M can be configured to provide several modes of operation. The configurable parameters are:

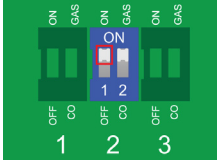

### Left switch on any of the 1st double DIP switch

The GS100M will not look for a sensor on a given zone if the switch is moved to the OFF position. It is not necessary to remove the return cable from the sensor.

**Example shows Zone 1 On.**

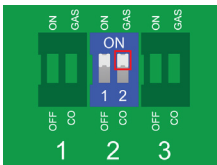

### Right switch on any of the 1st double DIP switch

Toxic or explosive levels. These are labelled as GAS or CO on PCB. The symbols on the front fascia of the detector are EN standard symbols and refer to any explosive or toxic gas. If toxic gas, e.g. carbon monoxide is to be sensed on a given zone move the switch to the CO position. If explosive, e.g. natural gas, LPG, hydrogen etc. move the switch to the GAS position.

**Example shows Zone 1 Explosive.**

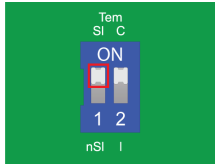

### Left switch on 2nd double DIP switch

Positive safety determines the condition of the main alarm relay and hence the operation of the gas valve. When it is 'ON' the relay is in a normally open state. When it is 'OFF' the relay is in a normally closed state. NOTE: This affects how the gas valve operates and means that you may need to change how it is wired to the GS100M. **Example shows Positive Safety on**

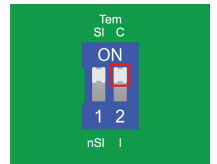

### Right switch on 2nd double DIP switch

Main Alarm relay actuation method. This can be configured to provide either a permanent or temporary alarm operation. When the main alarm is actuated in an alarm condition if the switch is in the 'C' position the relay will remain in this position for the entire period in which the gas concentration remains above the alarm threshold. If the switch is in the 'I' position the main alarm relay will actuate for 60 seconds and then will return to the running condition. The indication on the panel fascia and the audible alarm will still indicate main alarm. This mode of operation is used when using manual reset gas valves and battery back-up systems for extending standby battery life. **Example shows detector configured for a permanent main alarm**

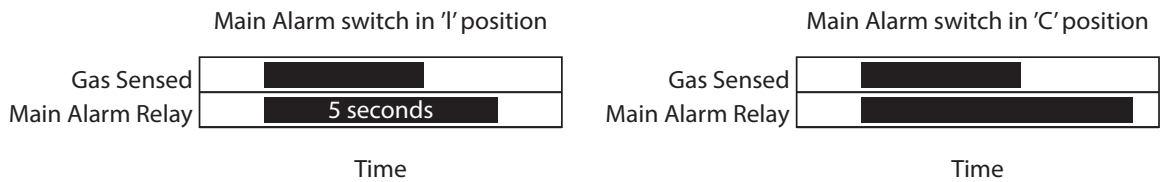

# GS100M wiring schematic

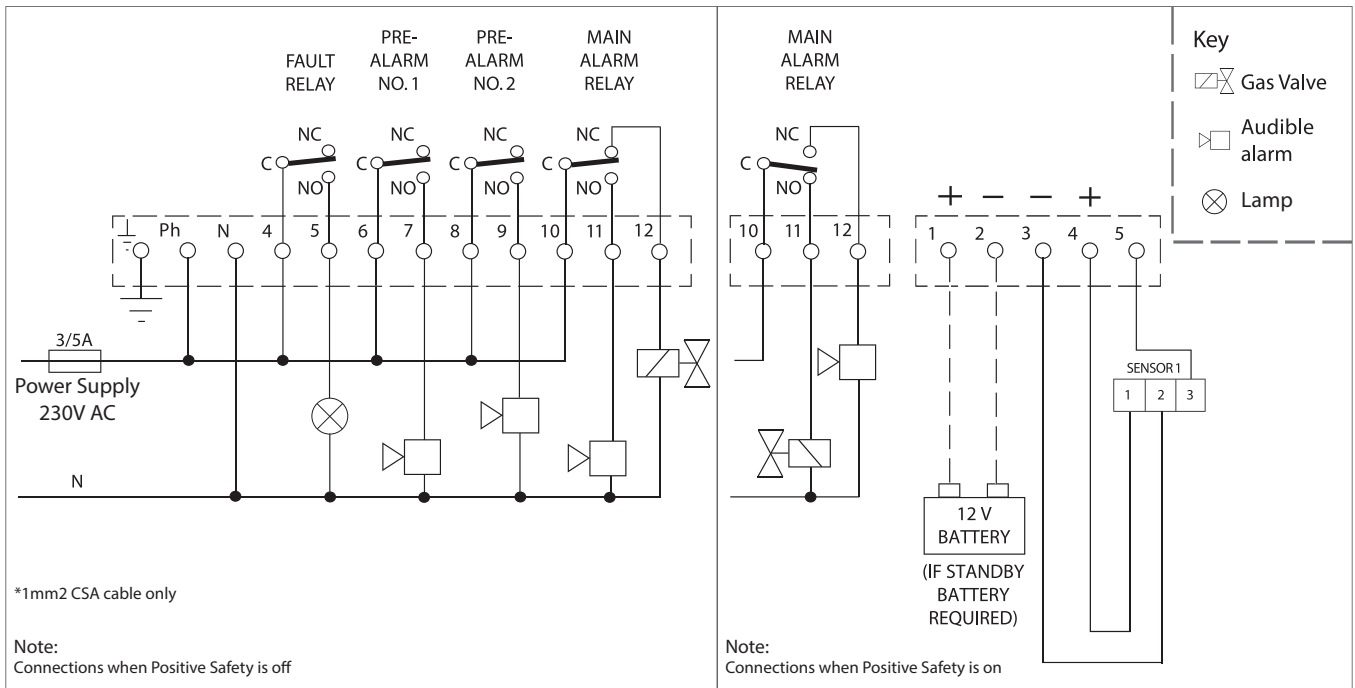

## Electrical Installation

The GS100M is a safety device designed to give audible alarms and automatically provide latched electrical isolation of associated gas safety shut off valves in the event of a gas leak or build up of toxic gases.

The sensors can be located up to 100m from the gas detector. Cable size should be 1mm<sup>2</sup> CSA. If the sensor cables are run separately in specific conduit it is not essential to use screened cable but if the cables are routed through conduit or trunking containing other wiring the use of screened cable is advisable. The wiring should be performed by a qualified person in accordance with current regulations. The plug-in terminal rail makes installation easy and quick. Do not mount close to any heat source or in an area where moisture is likely to effect operation. The IP rating of this unit is IP44. Sensors should be positioned as shown below.

If you require any guidance on this please call Duomo technical support on +44 1905 797989.

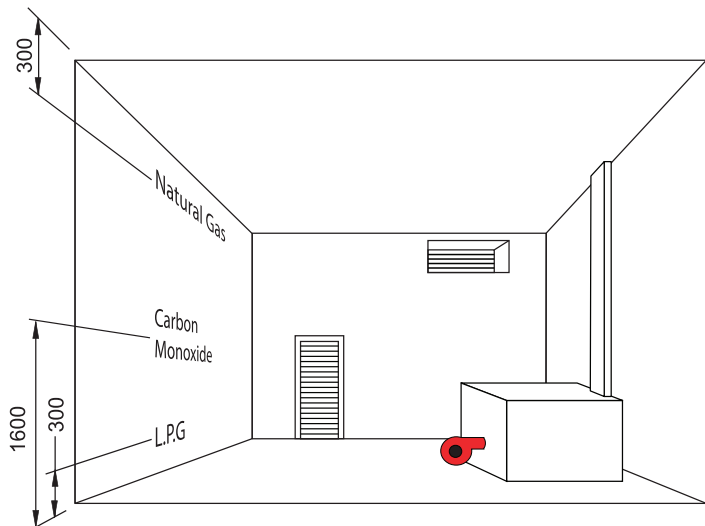

## Sensor Installation

The sensors must be mounted as shown below with the sintered head pointing vertically down. When replacing sensors never separate a sensing head from its PCB. The sensor will have been calibrated using this particular board and therefore will not function correctly with any other.

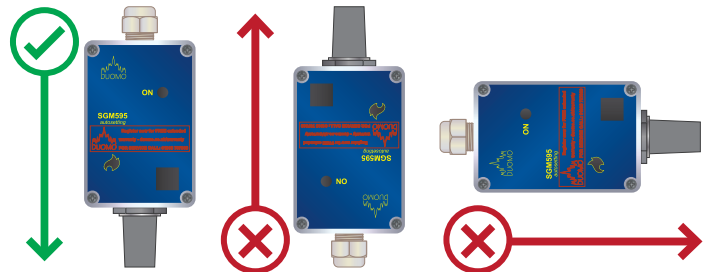

## Important Notes

Always check the wiring before powering up the system.

Do not test this sensor with anything other than Duomo test gas (See 'GS100M Operation' section for further information). Concentrations above this will damage the sensor and shorten sensor life.

The installation of this gas detector does not release the user from observing all the regulations concerning the characteristics of the installation and the use of gas appliances; the ventilation of the protected environment and the removal of products of combustion. Duomo will not be held responsible or liable for any damage caused to people, property or animals resulting from incorrect connection, installation or application of this gas detector. To ensure correct function after installation Duomo provide a commissioning service using calibrated test gases. For this service call +44 1905 797989.

## Sensor range for use with GS100M

### CO233A CO Sensor

4-20mA

8888  
Colour Change  
Digital Display

IP65



CO

#### Technical Specification

Gas(es) Detected	Carbon Monoxide
Dimensions	Width 100mm   Height 100mm   Depth 60mm
Display	6 Colour Digital Display
Sensor Technology	Electrochemical
Settings	Preset to TWA and STEL Standards
Output Signal	4-20mA
Sensor range	0-300ppm
Working Temperature	-20°C to +50°C
Autosetting	Yes
Protective Rating	IP65
Approvals	EN50270 & EN45544-1-3 Compliant

### CO100AR CO Sensor

4-20mA

IP55



CO

#### Technical Specification

Gas(es) Detected	Carbon Monoxide
Dimensions	Width 100mm   Height 100mm   Depth 60mm
Display	N/A
Sensor Technology	Electrochemical
Settings	Preset to TWA and STEL Standards
Output Signal	4-20mA
Sensor range	0-300ppm
Working Temperature	-15°C to +40°C
Autosetting	Yes
Protective Rating	IP55 (Enclosure) IP65 (Sintered Head)
Approvals	BS EN50291 Compliant

### HCF100 Refrigerant Gas Sensor

4-20mA

IP55



Freons

#### Technical Specification

Gas(es) Detected	Freons (Inc R134A, R404A, R407C, R410A)
Dimensions	Width 76mm   Height 150mm   Depth 58mm
Display	N/A
Sensor Technology	Semiconductor
Settings	N/A
Output Signal	4-20mA
Sensor range	0-300ppm
Working Temperature	-10°C to +60°C
Autosetting	Yes
Protective Rating	IP55
Approvals	EN50270 & EN45544-1-3 Compliant

### SGM595 Methane or LPG Sensor

4-20mA

IP55



Methane

Propane

#### Technical Specification

Gas(es) Detected	Methane and LPG
Dimensions	Width 73mm   Height 108mm   Depth 57mm
Display	N/A
Sensor Technology	Catalytic
Settings	N/A
Output Signal	4-20mA
Sensor range	5% to 20% LEL
Working Temperature	-10°C to +60°C
Autosetting	Yes
Protective Rating	IP55
Approvals	EN50194 Compliant

## Sensor range for use with GS100M

### SG895 ATEX Sensor

4-20mA

IP65



10+  
Gases

#### Technical Specification

Gas(es) Detected	Methane, LPG, Ammonia, Hydrogen, Acetylene, Gasoline, Methanol, Ethanol, White Spirit, Acetone, Hexane, Ethyl Acetate, Toluene
Dimensions	Width 100mm   Height 133mm   Depth 70mm
Sensor Technology	Pellistor
Settings	0-20% LEL (0-300ppm for Carbon Monoxide)
Output Signal	4-20mA
Sensor range	0 - 100% of LEL or diff. in ppm
Working Temperature	-10°C to +70°C
Autosetting	Yes
Protective Rating	IP65
Approvals	ATEX RATED EN60079-0, EN60079-1, EN61241-0 & EN61241-1 Compliance

### SG500 Methane or LPG Sensor

4-20mA

IP30



Methane

LPG

#### Technical Specification

Gas(es) Detected	Methane or LPG
Dimensions	Width 110mm   Height 50mm   Depth 35mm
Sensor Technology	Catalytic
Settings	N/A
Output Signal	4-20mA
Sensor range	0-20% LEL
Working Temperature	-0°C to +40°C
Autosetting	No
Protective Rating	IP30 (Enclosure)
Approvals	N/A

### SGF104 Oxygen Sensor

4-20mA

IP64



O<sub>2</sub>

#### Technical Specification

Gas(es) Detected	Oxygen
Dimensions	Width 100mm   Height 100mm   Depth 60mm
Sensor Technology	Optical (Fluorescence based)
Settings	19.5 or 18.5% of O <sub>2</sub> (depletion), 22.5, 23.5% (excess)
Output Signal	4-20mA
Sensor range	0-25%
Working Temperature	-30°C to +60°C
Autosetting	Yes
Protective Rating	IP64
Approvals	EN50104 and EN50270 Compliant

## Calibration Gas

Available in 12L & 110L Cannisters



Valves and other spares also available

# GS100M Operation test procedure

Before powering up the GS100M once again check that all electrical connections are correct.

- 1 Apply 230VAC supply to the Ph and N terminals. Ensure that the correct fuse is used in the supply (3A or 5A max)
- 2 All of the LEDs on the fascia will illuminate in sequence which allows an opportunity to visually check the functionality of all the LEDs. This process takes approximately 20 seconds.
- 3 The ON LED will remain flashing for 90 seconds. During this period the GS100M is in warm up phase. Gas detection functionality is not available during this period.  
When the ON LED remains stable the GS100M is in full operation mode.

**Please note: The GS100M is not in override, the following step will activate relay outputs when Alarm level readings are exceeded.**

By pressing and holding the TEST button a function test can be performed for all Pre-Alarm and Main Alarm relays together with LEDs and internal buzzer. If a full test is required then hold the TEST button until 300ppm or 20%LEL reading is exceeded to activate all relays.

The sequence will be:

- (a) At 8% LEL/ 120ppm reading - Pre-Alarm no.1 relay actuated, 1<sup>st</sup> ALARM LED illuminates and Terminal 6 and 7 will be connected.
- 4 (b) At 13% LEL/ 200ppm reading - 1<sup>st</sup> ALARM outputs listed in step (a) are all deactivated (Relay, LED and Terminal connections) . Pre-Alarm no.2 relay actuated, 2<sup>nd</sup> ALARM LED illuminates and Terminal 8 and 9 will be connected.
- (c) At 20% LEL/ 300ppm reading - The Main Alarm relay is actuated, MAIN ALARM LED illuminates and Terminal 10 and 11 will be connected and terminals 10 and 12 will be broken and the **audible alarm** will continue to sound (With Positive Safety On terminals 10 and 11 will be broken and terminals 10 and 12 will be connected).

The relevant Alarm LED will illuminate to show which zones are in alarm.

By releasing the TEST button the LED will go out and the audible alarm will stop. If latched alarm function on the main relay is configured this will remain on until the RESET button is pressed.

- 5 In order to conduct a full function test and calibration it is essential to use Duomo (UK) Ltd or equivalent calibrated test gas. The maximum concentrations are:  
40% Methane (CH<sub>4</sub>) in Air  
350ppm Carbon Monoxide (CO)  
0.85% (MOL) for Propane

Any higher can reduce sensor lifespan. Note: **NEVER TEST WITH NEAT GAS. THIS WILL POISON THE SENSOR.**

- 6 To simulate a sensor fault and test associated outputs:  
Disconnect the sensor plug The detector will go into FAULT ALARM and the sensor fault relay will be actuated as well as the FAULT LED. This will close the contacts between terminals 4 and 5 and open the contacts between terminals 10 and 12 (Main Alarm relay). When the plug is reconnected the detector can be reset by pressing the RESET button.



## In case of alarm

Extinguish any naked flames.

Do not switch lights or electrical devices on or off.

Open all windows and door to increase ventilation.

- If the ALARM LED is off the levels of gas have dropped. A responsible, qualified person is now safe to find the cause of the alarm.
- If the alarm sound remains constant and the cause is not evident or not possible to eliminate turn off the emergency isolation valves to the area and contact your gas provider emergency line. They will advise accordingly.

## Troubleshooting

The Problem	The Solution
No light are illuminated on the fascia of the detector	Check that the electrical supply is reaching the device and that the plug in terminal rail is pushed into place.
One or all of the sensor fault lights are illuminated	Check that the plug is inserted correctly. Check that the sensor wiring is correctly terminated at both the detector and the sensor. Check that 12V DC is present at the sensor. The green LED on the sensor should be illuminated. By pressing the TEST button on the detector fascia it is possible to check the efficiency of the device and if the sensors have been connected correctly.
Sensor fault continues to alarm	Check the sensor wiring. If the red Overload LED is illuminated then a short circuit or overload has occurred on the sensor or connecting cable.
The detector is subject to repeated alarms	Ensure that there is not an occasional gas leak. This may be due to a valve or joint which leaks under pressure.
The detector is in main alarm condition and the main gas valve is not closing	Check that the connections are correct and that power is supplied to the valve i.e. The valve is not stuck in the open position. The function of the alarm relays both the Pre-Alarm and the Main Alarm can be checked by pressing the TEST button on the detector fascia. Check that the main alarm action is configured for a latching alarm. <b>(Switch 2 on 5th DIP switch - See Configuring the GS100M)</b>
There is no supply to the solenoid valve	The Main Alarm relay is a volt free contact, therefore you must connect the live supply to the common of the main alarm relay contacts terminal 10. A supply will then come from terminal 12 to the solenoid valve.
The sensor is connected but no LED is lit on the front fascia	Check that the DIP switch is set to the ON position for that sensor <b>(Switch 1 on one of the first three DIP switches - See Configuring the GS100M)</b>

### Still experiencing difficulties?

If you have made the checks above and are still experiencing difficulties then please call **Duomo (UK) Ltd** on **+441905 797989** for technical assistance.

# Commissioning, Service & Maintenance

## Commissioning

It is strongly recommended that this GS100M gas detection system is commissioned and serviced by Duomo Commissioning Engineers or engineers approved by Duomo. A quotation for commissioning or service will be provided upon request.

Email site details and preferred date for commissioning or service to [sales@duomo.co.uk](mailto:sales@duomo.co.uk) to the Duomo Service Department. Or call **+44 1905 797989**

The benefits of this equipment being commissioned by Duomo are:

- **On board spares** - If for whatever reason this equipment doesn't function correctly Duomo engineers will have spares on board to ensure that the commissioning is successful.
- **A Duomo Commissioning Certificate is provided** - A certificate from the original manufacturer ensures that the commissioning or servicing carried out is at a high professional standard by a competent and qualified service engineer.

It is prudent to make electrical connection to the detector terminal plus when withdrawn and leave the plug off the detector so that the Duomo Engineer is the first to power up the unit on site. This allows wiring to be checked prior to commissioning and avoids damage due to incorrect connection. Guarantees for this product will become void if damage is caused by the installer.

## Maintenance

This detector must be function checked as described above using calibrated test gas every 6 months.

To arrange for a Duomo engineer to conduct this work or to arrange a service contract please call **+44 1905 797989**.





## GS100M 23092022 rev5

This document is protected by copyright ©  
No changes by others are permitted without prior authorisation by Duomo (UK) Ltd.  
Duomo (UK) Ltd reserve the right to modify and revise this datasheet without notification.

01905 797989

[www.duomo.co.uk](http://www.duomo.co.uk)  
[sales@duomo.co.uk](mailto:sales@duomo.co.uk)

 [linkedin.com/company duomo-uk](https://www.linkedin.com/company/duomo-uk)

 @DuomoUK

5 The Furlong, Berry Hill Industrial Estate, Droitwich, Worcestershire, WR9 9AH