

User Manual

aSENSE

CO₂ / temperature transmitter

General

The IAQ-sensor product *aSENSE* is used to measure indoor air carbon dioxide concentration and temperature in rooms. The *aSENSE* is available both with and without display, (LCD). Both are available for wall mounting as well as for duct mounting.

The unit is designed for connecting to Direct Digital Control (DDC). The linear output functions are pre-programmed as CO₂ and temperature transmitters with jumper selected outputs 0-10 V / 2-10 V / 0-20 mA / 4-20 mA. The measuring ranges can be modified from a PC (Windows NT, XP, 7) and use of the software UIP (version 5 or higher) together with the RS232 communication cable.



Figure 1 aSENSE for wall mounting and duct mounting

Terminal	Default Output	Default Output Range	Outputs of this sensor	Output Range of this sensor
Out(1)	0-10VDC	0-2000 ppm CO ₂		
Out(2)	0-10VDC	0-50 °C 32-122 °F		

Table I. Default output configurations for aSENSE

Formulas for calculation of output values

Configuration	Output Range	Formula for calculation
0-10 VDC	0-2000 ppm CO ₂ 0-50 °C 32-122 °F	CO ₂ value = Volt/10*2000 Temperature value in °C = Volt/10*50 = Volt*5 Temperature value in °F = Volt*9+32
2-10 VDC	0-2000 ppm CO ₂ 0-50 °C 32-122 °F	CO ₂ value = (Volt -2)/8*2000 Temperature value in °C = (Volt -2)/8*50 Temperature value in °F = (Volt -2)/8*(122-32)+32
4-20 mA	0-2000 ppm CO ₂ 0-50 °C 32-122 °F	CO ₂ value = (mA-4)*2000/16 Temperature value in °C = (mA-4)*50/16 Temperature value in °F = (mA-4)/16*(122-32)+32
a-b	c-d	Value = (reading-a)/(b-a)*(d-c)+c a = lowest value of the configuration b = highest value of the configuration c = lowest value of the range d = highest value of the range

Table II. Calculation of CO₂ value and temperature value for aSENSE

Output Configurations

The sensors/controllers are supplied from the factory (unless otherwise ordered) with 0...10VDC linear outputs for Out(1) and Out(2) (see Table I). If other options are needed for the application, the output jumpers have to be configured before the unit is powered up. Each jumper selection is independent from the others, except for the "Start point selection" jumper, which affects both Out(1) and Out(2) linear outputs. Alternative measuring ranges of the outputs can be selected with the software UIP (version 5 or later).

Jumper	Position	Function
Start point selection jumper	0%	Jumper top position provides 0Vdc or 0mA start point for Out(1), Out(2) (0-20mA or 0-10V).
	20%	Jumper bottom position provides 2Vdc or 4mA start point for Out(1), Out(2) (4-20mA or 2-10V). NOTE! The start point jumper is missing on some models!
Out(1)	Current	Connection in position "Current" provides 0/4-20mA output range for Out(1). Current output is not recommended for temperature measurements
	Voltage	Connection in position "Voltage" provides 0/2-10VDC output range for Out(1). Please note! Temperature measurements accuracy is valid only for units configured in voltage outputs mode.
Out(2)	Current	Connection in position "Current" provides 0/4-20mA output range for Out(2). Current output is not recommended for temperature measurements
	Voltage	Connection in position "Voltage" provides 0/2-10VDC output range for Out(2). Please note! Temperature measurements accuracy is valid only for units configured in voltage outputs mode.

Table II. Configuration jumpers for aSENSE

Self-diagnostics

The system contains complete self-diagnostic procedures. A full system test is executed automatically every time the power is turned on. In addition, constantly during operation, the sensor probes are checked against failure by checking the valid dynamic measurement ranges. All EEPROM updates, initiated by the sensor itself, as well as by external connections, are checked by subsequent memory read back and data comparisons. These different system checks return error bytes to the system RAM. The error codes are available by connecting a PC with a special RS232 cable connected to the UART port slide connector. The error codes are shown in the software UIP (version 5 or later). *Warm up* and *Out of Range* are the only bits that are reset automatically after return to normal state. All other error bits have to be reset manually after return to normal by power off/on.

The yellow LED lights yellow at heating phase after power up and if an error has been detected.

Error code and action plan

Bit #	Error code	Error description	Suggested action
0	N/A	Fatal Error	Try to restart sensor by power OFF/ON. Contact local distributor
1	2	Reserved	
2	4	Algorithm Error. Indicate wrong EEPROM configuration.	Try to restart sensor by power OFF/ON. Check detailed settings and configuration with UIP software version 5 and higher. Contact local distributor.
3	8	Output Error Detected errors during output signals calculation and generation.	Check connections and loads of outputs. Check detailed status of outputs with UIP software version 5 and higher.
4	16	Self-Diagnostic Error. Algorithm timeout	Check detailed self-diagnostic status with UIP software version 5 and higher. Contact local distributor
5	32	Out of Range Error Accompanies most of other errors. Resets automatically after source of error disappearance.	Try sensor in fresh air. Check connections of temperature and relative humidity probe. Check detailed status of measurements with UIP software version 5 and higher. <i>See Note 1!</i>
6	64	Memory Error Non-fatal error during memory operations.	Check detailed settings and configuration with UIP software version 5 and higher.
7	128	Warm Up state Is always set after power up or power failure. Resets after restart sequence.	If it doesn't disappear in half a minute, check power stability.

Note 1. Any probe is out of range. Occurs, for instance, during over exposure of CO₂ sensor, in which case the error code will automatically reset when the measurement values return to normal. Could also indicate the need of zero point calibration. If the CO₂ readings are normal, and still the error code remains, the temperature sensor can be defect or the connections to it are broken.

Remark: If several errors are detected at the same time the different error code numbers will be added together into one single error code!

PLEASE NOTE! The sensor accuracy is defined at continuous operation (at least 3 weeks after installation)

Maintenance

The *aSENSE* is basically maintenance free. An internal self-adjusting calibration function takes care of normal long term drift associated to the CO₂ sensor. To secure the highest accuracy, a time interval of five years is recommended between CO₂ calibrations, unless some special situations have occurred. A zero calibration can be performed by use of pure nitrogen or air that has passed through a chemical absorber and a PC together with the *UIP software version 5* (or higher). The Zero Calibration bag can be used to produce carbon dioxide free air. The software can be free downloaded from www.senseair.com. The RS232-cable and the zero calibration bag can be ordered from SenseAir. The cable is to be connected to the UART port slide connector (see Fig. 5). For change of control parameters and re-calibration (CO₂ and temperature) this PC tool has to be used. The check can be done on site without interfering with the ventilation system. Re-calibration can be done with a PC or by shortening of marked holes for at least 10 seconds.

A Back-ground calibration is an easy way to correct a sensor's zero point. The sensor needs fresh air (380-420 ppm CO₂). Shorten marked holes for at least 10 seconds.

This is for sensors with measuring ranges between 0-3000 ppm and 0-4%:

When a zero calibration shall be executed a plastic tube with 2.2 mm outer diameter and 0.8 mm inner diameter shall be inserted in marked holes of the sensor. Plastic tubing is connected to the tube. The gas flow should be between 0.3 and 1.0 l/min. Shorten marked holes for at least 10 seconds. A successful calibration is acknowledged by 5 flashes of the yellow LED. If unsuccessful, please release input and waits at least 10 seconds before repeating the procedure again. Make sure that the sensor environment is steady and calm!

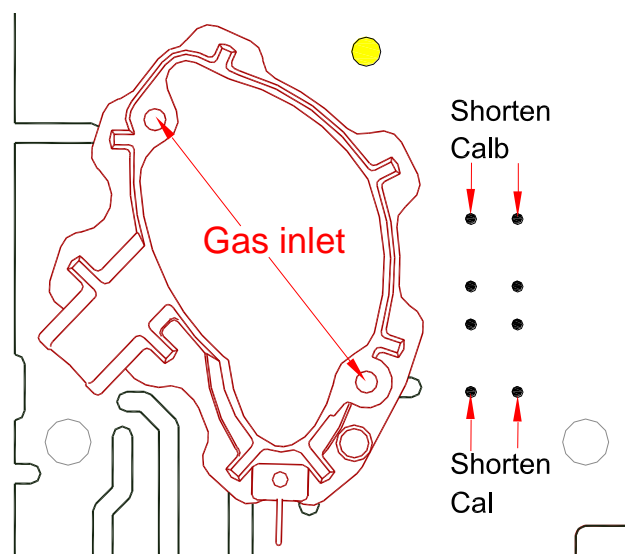

Figure 2 Part of the PCB with holes for gas inlets marked.

Duct mounting

If for some reason the printed circuit board (PCB) needs to be removed, special precaution must be taken in order not to damage the temperature probe in the sampling tube. When putting the PCB back in the protective housing, the probe must be gently positioned in the sampling tube.

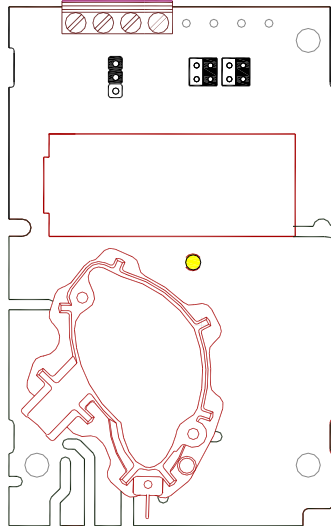

Figure 3 The aSENSE printed circuit board

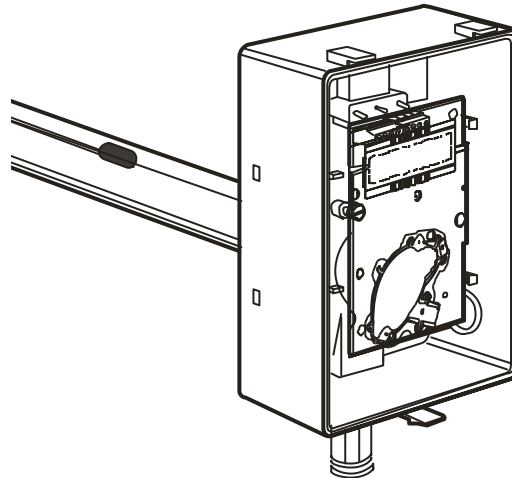

Figure 4 The aSENSE for duct mounting. The temperature probe is the black body in the sampling tube.

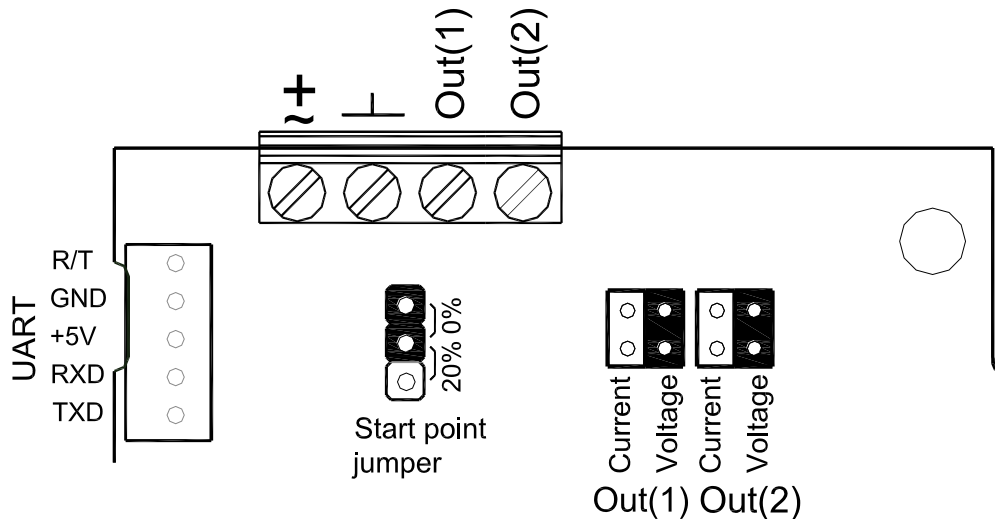

Figure 5 Terminals and jumpers on aSENSE. The darker positions are default settings. The start point jumper is not mounted on some models.

WARRANTY AND LIMITATION OF LIABILITY

1. SenseAir warrants that for a period of twenty-four (24) months following receipt by Buyer the Product supplied by SenseAir to Buyer will be, under normal use and care, free from defects in workmanship or material and to be in material conformity with SenseAir's specifications. Units returned to SenseAir for warranty repairs shall be shipped to SenseAir, at Buyer's expense, according to SenseAir's instruction. Within ninety (90) days of the receipt of product, SenseAir shall replace or repair such units and shall ship them to Buyer's designated return destination freight pre-paid.

2. Warranty Limitations. This warranty does not extend to any unit that has been subject to misuse, neglect or accident; that has been damaged by causes external to the unit; that has been used in violation of SenseAir's instructions; that has been affixed to any non-standard Accessory attachment; or that has been modified, disassembled, or reassembled by anyone other than SenseAir.

3. The retailer is not responsible for any consequential loss or damages, which may occur by reason of purchase and use of this product. The warranty is, in any event, strictly limited to the replacement/repair of the product

This product is in accordance with the
EMC 2004/108/EC, 92/31/EEG
including amendments by the CE-marking Directive 93/68/EEC
The product fulfils the following demand:

EN 61326-1:2006, Class B equipment, Table 1 - *Basic immunity test requirements*

